



## Product Installation Guide

# Zen Ice Spa

Provides any two cold drinking water options. Choose from a combination of ;  
 Filtered or unfiltered cold (ambient) water when connected directly to the mains supply  
 Filtered or unfiltered cold (chilled) water when installed with an undersink chiller (supplied separately, see separate instructions for install)

### Contents

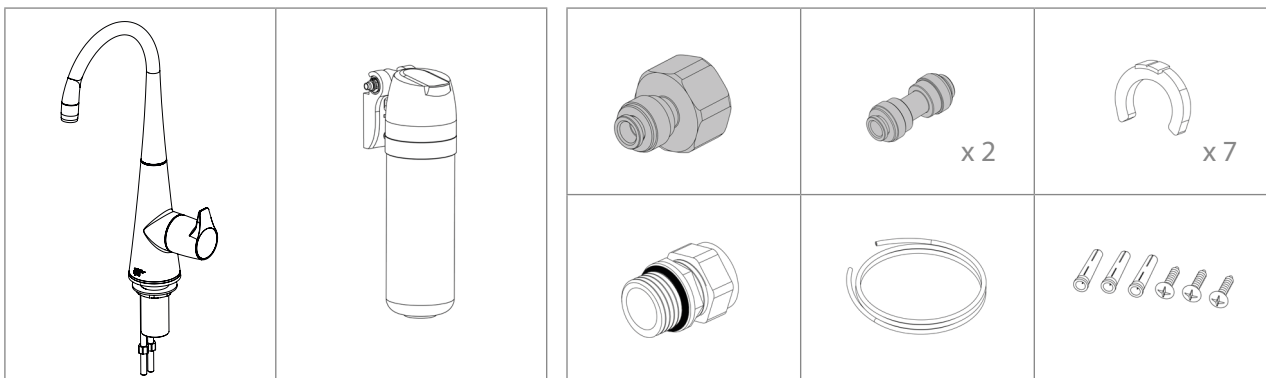

The required hole diameter is 32 mm. Can be installed onto a sink/ countertop up to 50 mm thick.  
 Distance between centres - tap base to spout is 140 mm. Ensure this meets installation requirements.

### Installation Steps

<p>1</p>	<p>2</p>
<p>The o- ring sits in a groove on the underside of the tap and is to be positioned on top of the mounting surface, the metal washer and retaining nut go on the underside.</p>	<p>Insert the grey 1/4" to 1/4" push fit connectors onto each stem of the tap until a full stop is reached. Pull back each push fit connector to test for a solid connection and then insert a locking collar onto each to prevent future inadvertent removal.</p>

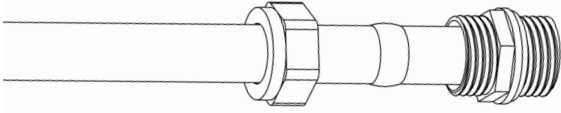
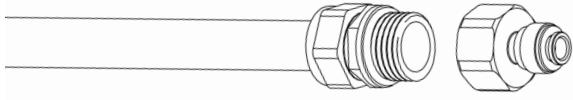
<p>3</p> 	<p>4</p> 
<p>Make a connection to the incoming cold-water supply using the brass compression fitting.</p>	<p>Attach the plastic 1/2" BSP to 1/4" push fit connector by screwing onto the brass fitting.</p>

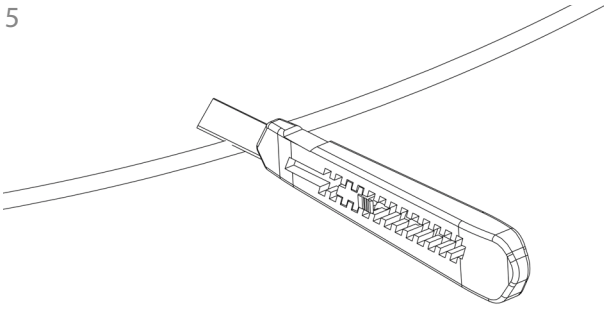
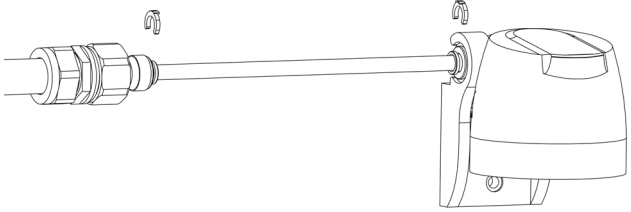
<p>5</p> 	<p>6</p> 
<p>With a sharp knife, cut the 1/4" tubing (ensure a straight cut and avoid crushing the tubing) to the required length for connection to the filter head "In" side.</p>	<p>Push the tube firmly into each fitting (pull gently to confirm good connection) and insert locking collar (ensure no kinks in the tubing).</p>

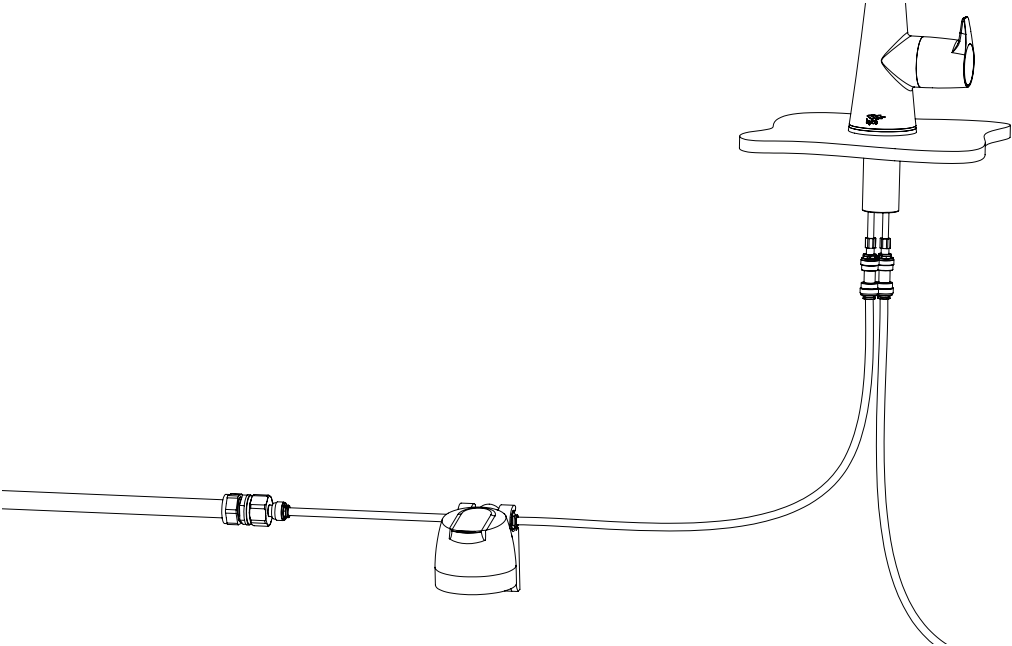
<p>7</p> 
<p>Calculate and cut the remaining section of 1/4" tubing and make the final connections between fittings as per step 6. The remaining tap inlet should facilitate connection to the second cold drinking water selection. If this is unfiltered cold (ambient) follow steps above without a filter in the 1/4" tubing. If chilled water is required follow separate chiller instructions.</p>

Supplied drinking water filter must be changed every 6 months or when the rated capacity is reached, whichever comes first.

The tap is covered by a standard parts or replacement warranty for a period of 2 years from the date of purchase.

If you experience a problem with this product you should first contact our service department on 01924 225 200 before taking any further action. Experience has shown that issues can often be resolved without the need to return or uninstall the product.

