

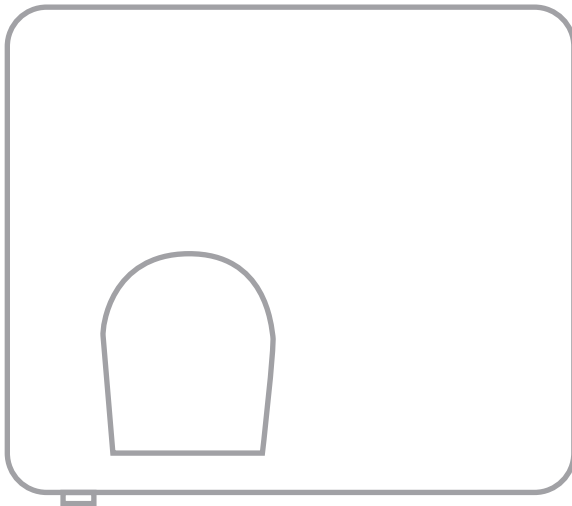

Product Instruction Manual

Tornado



TOR25W (white), **TOR25BSS** (brushed stainless steel)

2.5kW automatic hand dryer

Thank you for purchasing the Hyco Tornado hand dryer. The Tornado is a traditional high powered hand and face dryer suitable for a wide range of applications including restaurants, shops and shopping centres, office buildings, pubs, motorway services, factories and supermarkets. Please read and understand these instructions before commencing installation, and leave them with the user when installation is complete.

1. Important safety points

- The Electrical installation must be carried out by a qualified electrician in accordance with the current edition of the I.E.E. Wiring Regulations.
- This appliance must be earthed.
- Means for electrical disconnection must be incorporated in the fixed wiring in accordance with the wiring rules.
- Only connect the hand dryer to a single phase supply with a mains voltage as specified on the rating plate.
- The hand dryer must be fixed out of reach of a person taking a bath or shower.
- This appliance can be used by children aged from 8 years and above and persons with reduced physical, sensory or mental capabilities or lack of experience and knowledge if they have been given supervision or instruction concerning use of the appliance in a safe way and understand the hazards involved. Children shall not play with the appliance. Cleaning and user maintenance shall not be made by children without supervision.
- Do not cover the air inlet or outlet.
- Ensure nothing is located within a minimum of 40cm below the air outlet.

2. Installation

Wall Mounting



The hand dryer must be fixed out of reach of a person taking a bath or shower.



Ensure that the surface selected for mounting the hand dryer is suitable for the weight of the product.



Ensure nothing is located within a minimum of 40cm below the air outlet.

- Select a suitable location for the hand dryer.

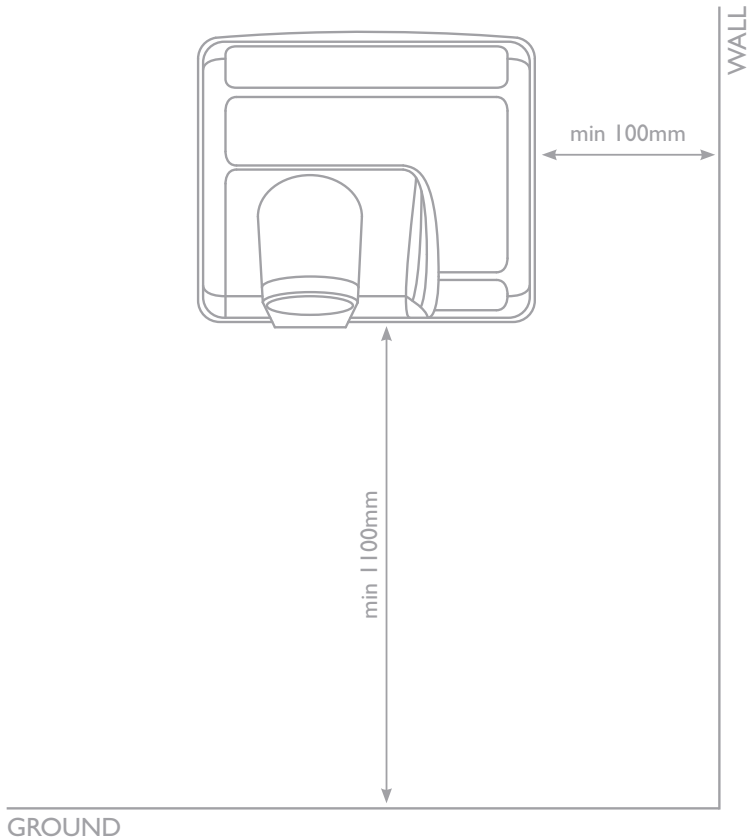

- Remove the two screws located at the bottom of the unit with the Allen key provided.
- Carefully uncouple the sensor wire before removing the front cover completely.
- Mark and drill the four holes to a depth of at least 40mm. Insert the four wall plugs provided.

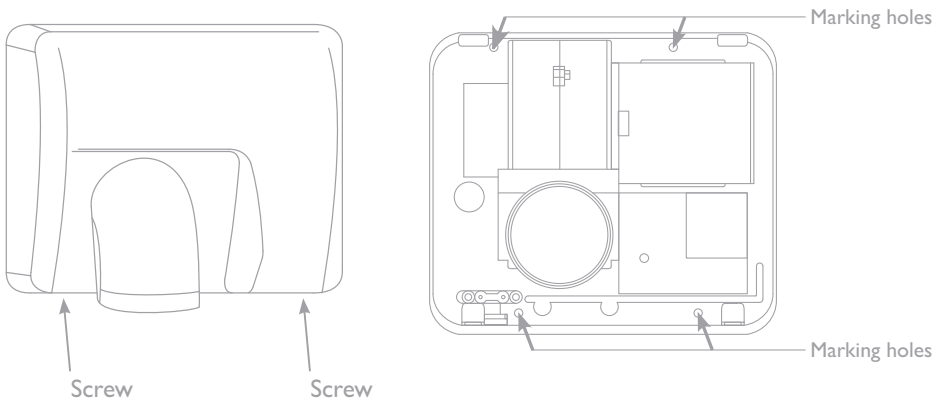

- Use the four screws provided to screw the back plate firmly to the wall.

Electrical



This appliance must be earthed.



Means for electrical disconnection must be incorporated in the fixed wiring in accordance with the wiring rules

- The power cord should be connected following the colour coding below:
 - Brown: L
 - Blue: N
 - Green / Yellow: E
- Reconnect the sensor wire and replace the cover; ensuring the cover is tightly fitted to the base.

3. Operation

- Shake excess water from hands.
- To activate the hand dryer, place your hands underneath the air outlet to operate the sensor.
- Rub hands together lightly and rapidly.
- The dryer will stop automatically after removing hands.
- The dryer will also automatically cut-out after 1 minute of consecutive use.
- To re-start the hand dryer, put hands back underneath and re-operate the sensor.

4. Maintenance



Always isolate the hand dryer from the power supply before commencing any maintenance.



Never use abrasive chemicals or materials to clean the hand dryer.

- Clean the exterior of the unit using a soft, damp cloth

5. Specifications

Voltage	230V~50Hz
Power	2.5kW
Air speed	30m/s
Sound level	75dB
IP Rating	IPX1
Weight	6.0kg

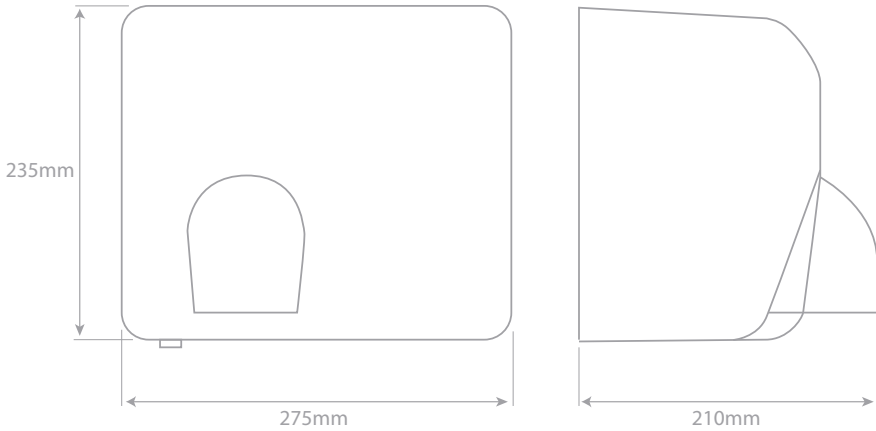

6. Guarantee and service policy

This product is guaranteed against faulty materials and manufacture for a period of one year from the date of purchase. Hyco will in its sole discretion replace, repair or refund any faulty unit. Incorrect installation and failure to follow correct operating instructions are excluded. Consequential costs such as labour charges or damage to surroundings are expressly excluded.



INFORMATION FOR CORRECT DISPOSAL OF THE PRODUCT IN ACCORDANCE WITH THE EUROPEAN DIRECTIVE 2012/19/EU.

At the end of its working life this equipment must not be disposed of as household waste. It must be taken to a local authority waste collection centre or to a dealer providing this service. Disposing of electrical and electronic equipment separately enables its components to be recovered and recycled to obtain significant savings in energy and resources. In order to underline the duty to dispose of this equipment separately, the product is marked with a crossed out dustbin.

Hycos Manufacturing Ltd
Normandy Court
Express Way
Castleford, WF10 5NR

T 01924 225 200
F 01924 225 210
E sales@hycos.co.uk

hycos.co.uk