

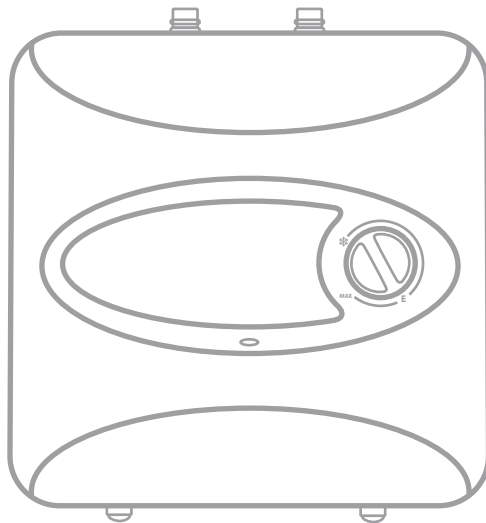

Product Instruction Manual

Speedflow



SF10SS & SF15SS
Stainless Steel

Undersink unvented water heater

Thank you for purchasing a Hyco Speedflow unvented water heater. The Speedflow is ideal for use in cloakrooms and kitchens in offices, shops, student accommodation and domestic premises which have been extended and there is no central hot water system nearby. One unit located under the kitchen sink is often used to supply hot water for light dishwashing in the kitchen sink and hand washing in the cloakroom basin. Please read and understand these instructions before commencing installation and leave them with the user when installation is complete.

1. Important safety points

Important information is contained within this instruction manual, read and understand the safety guidance and warnings before undertaking installation, operation or maintenance of the appliance. Ensure they are left with the user upon completion of installation.



Electrical installation must be carried out by a qualified electrician in accordance with the latest edition of the IEE wiring regulations.



The appliance must be earthed.



The product should only be connected to an electrical supply that meets the specifications detailed on the rating label.



If the supply cord is damaged, it must be replaced by the manufacturer, its service agent or similarly qualified persons in order to avoid hazard.



The appliance can be used by children aged from 8 years and above and persons with reduced physical, sensory or mental capabilities or lack of experience and knowledge if they have been given supervision or instruction concerning use of the appliance in a safe way and understand the hazards involved.



The supplied safety relief device must be fitted in all circumstances, ensure there are no obstructions in the plumbing between it and the appliance.



The safety relief device will operate if it encounters an over pressure event, ensure it can discharge to a safe visible place, open to the atmosphere, that will not cause harm to people or the surroundings.



Turn off the appliance immediately if the water supply is suspected to be frozen. Consider reducing the risk by lagging pipework if exposed to cold environments.



The water stored in this appliance can be very hot when running on the higher thermostat settings. Ensure precautions are taken to inform and safe guard likely users, consider temperature limiting devices such as thermostatic mixing valves where the risk of scalding injury cannot be easily managed.

2. Installation

When choosing the installation location for the appliance, consider the following:

- Ease of future access for cleaning and maintenance.
- Minimising risks to property should a leak occur.
- Minimising the distance to desired outlet(s) to reduce heat losses through pipework.
- Risk of pipework freezing during cold periods.

The appliance can be installed as free standing or wall mounted, the required bracket and fittings for wall mounting are supplied.



The appliance can be installed above or below any outlet, but must be installed upright, with the plumbing connections exiting the top of the heater. The heater controls will malfunction in any other orientation and may pose a serious scalding risk.



If the appliance is to be wall mounted, ensure the wall is suitable for both the wall fixing types supplied, as well as being able to support the overall weight of the product when full of water (see specification table).

Wall Mounting

Using the wall mounting bracket supplied and ensuring a horizontal level, mark the two holes onto the mounting surface. Drill the two marked holes and then assemble the bracket and fixings, as shown, before inserting them into the holes.

Using a 10mm spanner, tighten both bolts until the bracket is firmly held on the mounting surface.

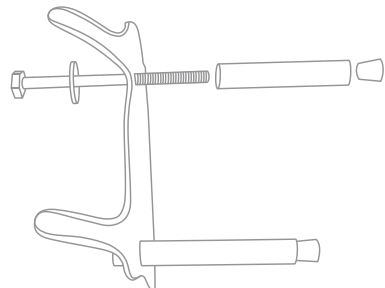

Offer the unit up to the bracket and engage it into the corresponding slots on the back of the unit. Ensure the bracket drives fully into the insulation of the heater and that it sits flush to the surface upon completion.

Plumbing

Before commencing the installation of any unvented water heater, a number of scenarios may require the additional purchase and installation of accessories in order to avoid problems of over pressure/drinking water contamination.

Check the below diagrams to confirm if any additional kit is required.

DIAGRAM A - Pressure < 4.2 bar & pipework length > 1.4m (5 litre)
2.8m (10 litre)
4.2m (15 litre)

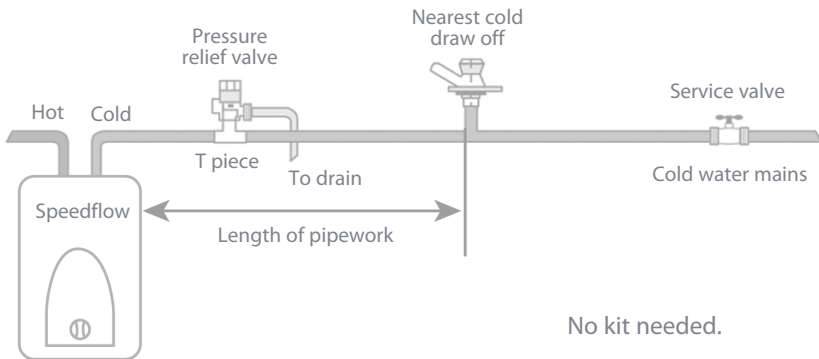

DIAGRAM B - Pressure > 4.2 bar & pipework length > 1.4m (5 litre)
2.8m (10 litre)
4.2m (15 litre)

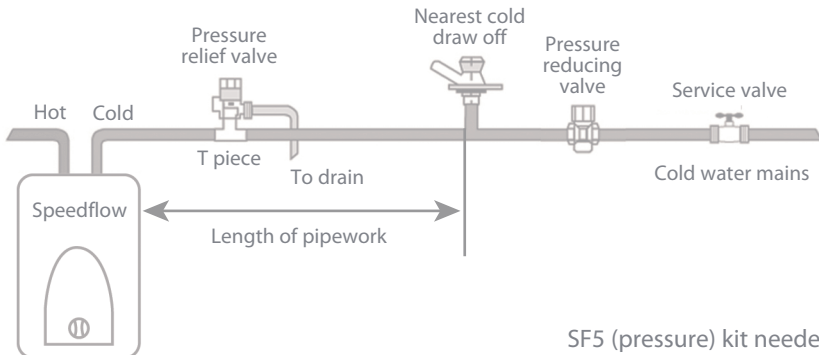
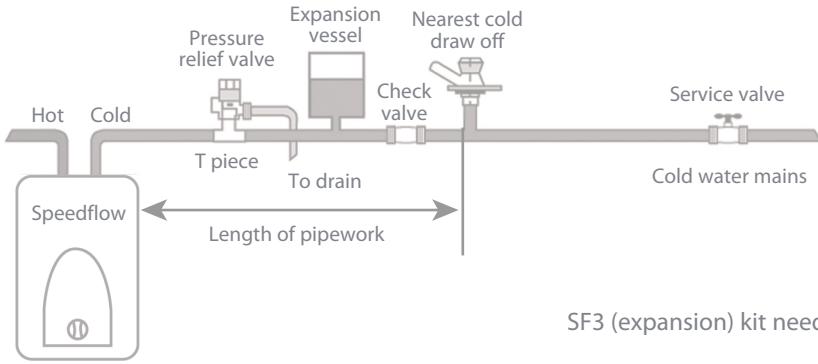
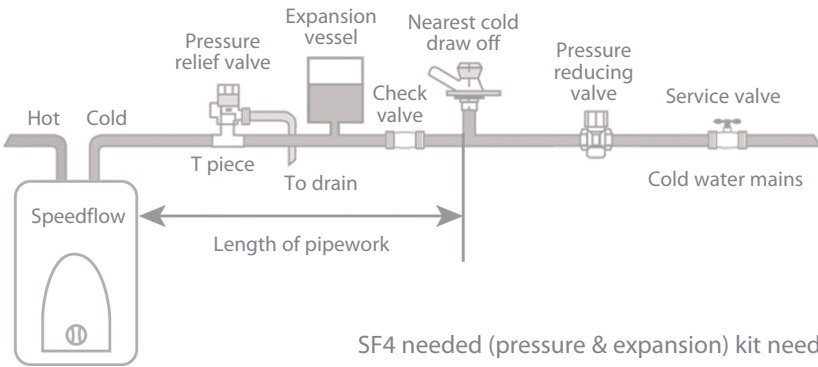

DIAGRAM C - Pressure < 4.2 bar & pipework length < 1.4m (5 litre)
 2.8m (10 litre)
 4.2m (15 litre)



SF3 (expansion) kit needed.

DIAGRAM D - Pressure > 4.2 bar & pipework length < 1.4m (5 litre)
 2.8m (10 litre)
 4.2m (15 litre)



SF4 needed (pressure & expansion) kit needed.

When planning the plumbing requirements for the heater, it is strongly advised a service valve be fitted nearby to facilitate future maintenance.

The inlet (blue) and outlet (red) connections are not interchangeable, it is essential that the incoming water supply is connected to the blue side and the red side is connected to the outlet (tap).

Both the inlet and outlet connections should be made using 1/2" female connections. For the best results, a fitting with a shallow thread depth is recommended. This will facilitate a good flush fit against the heater connections that will seal reliably when using a rubber washer of the right size.

Upon completion of all plumbing connections, open the outlet (tap) and then turn on the water supply to allow the unit to purge air and fill. When water runs smoothly from the outlet (tap), close it and then inspect all connections for leaks.



All installations require that the pressure relief valve (supplied) be fitted. When fitting it, ensure that there is a clear pathway (i.e. no check valves or non-return device) from the inlet of the heater right back to the device. Ensure the pressure relief valve discharges to safe visible place and an air gap is maintained.

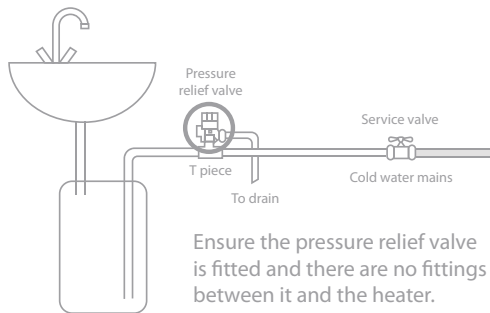

Failure to ensure the correct installation of the pressure relief valve may result in a dangerous build of pressure which can cause damage to the heater, fittings and surroundings. If in doubt contact a suitably qualified tradesman or alternatively speak to the technical team at Hyco about this, or any other question regarding the heater and its installation.

Electrical connection



Always isolate the power supply before any electrical work.



Ensure the appliance is completely full of water before electrical power on.

Connection should be made to the fixed wiring of the property via a double pole switched fused spur.

Electrical connections should be made as follows:

Green/Yellow earth wire to the terminal marked "E" or 

Brown/Red live wire to the terminal marked "L"

Blue/Black neutral wire to the terminal marked "N"

3. Operation

Once the electrical supply is switched on, the heater will maintain the temperature selected via the knob located at the front of the product.

The temperature can be adjusted by the user.

Settings are as follows:

"*" setting	5°C
"E" setting	50°C
"MAX" setting	75°C

The neon light on the front of the heater will illuminate when the heating element is working. When the light goes out this indicates the water has reached the thermostat set point.

4. Maintenance



Always ensure the appliance is isolated from the power supply before any maintenance or repair work.

Cleaning the heater

Use clean soapy water and non-abrasive cloths to clean the outside of the heater.

Sacrificial anode

A magnesium sacrificial anode is fitted to the heating element to protect the tank from corrosion. This should be inspected at least annually, or more frequently in areas with known aggressive water conditions, and replaced where necessary.

Pressure relief valve

The pressure relief valve should be checked annually by twisting the cap and verifying water is discharged and the valve reseals.

Element

Limescale can build up over time and seriously hamper the performance and life of the heating element. Check and descale the element annually, or more frequently if the installation is in a particularly hard water area.

Accessing the unit

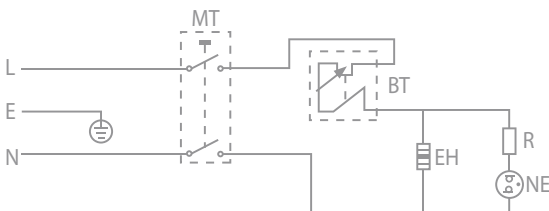
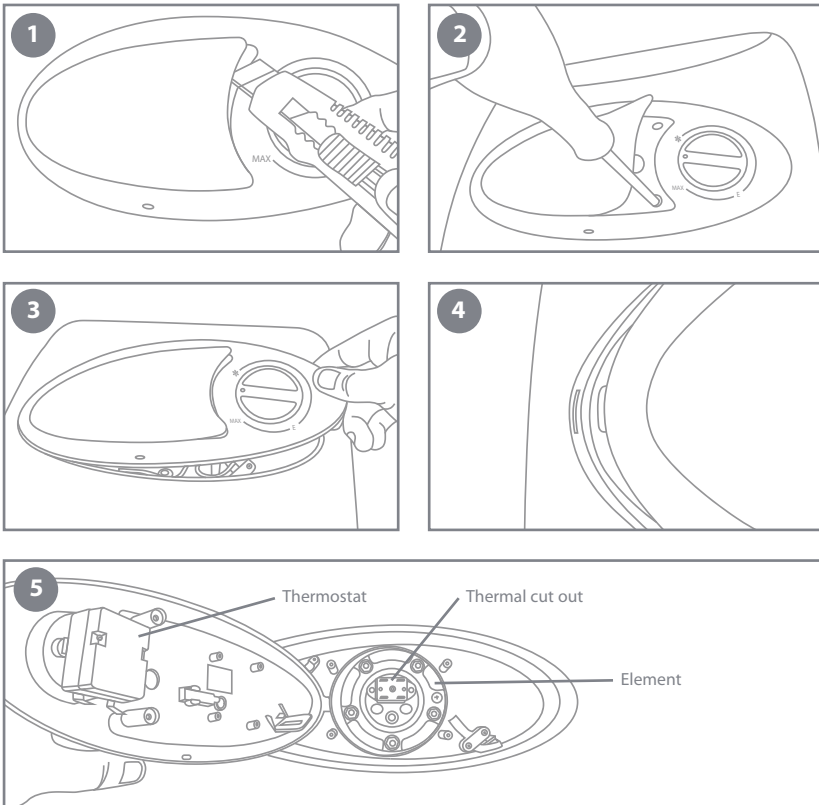

5. Specifications

	SF10SS	SF15SS
Supply	230V AC 50Hz	230V AC 50Hz
Power	2.0kW	2.0kW
Capacity	10L	15L
Max pressure	4.2bar(0.42MPA)	4.2bar(0.42MPA)
Pressure relief vale	6.0bar(0.6MPA)	6.0bar(0.6MPA)
Water resistance	IPX4	IPX4
Thermal protection	85°C (manual reset)	85°C (manual reset)
Class	I	I
Weight empty/full	7/17kg	8/23kg
Tank material	Stainless Steel	Stainless Steel

Product	A	B	C	D	E
SF10SS	330mm	330mm	291mm	21mm	100mm
SF15SS	366mm	366mm	327mm	21mm	100mm

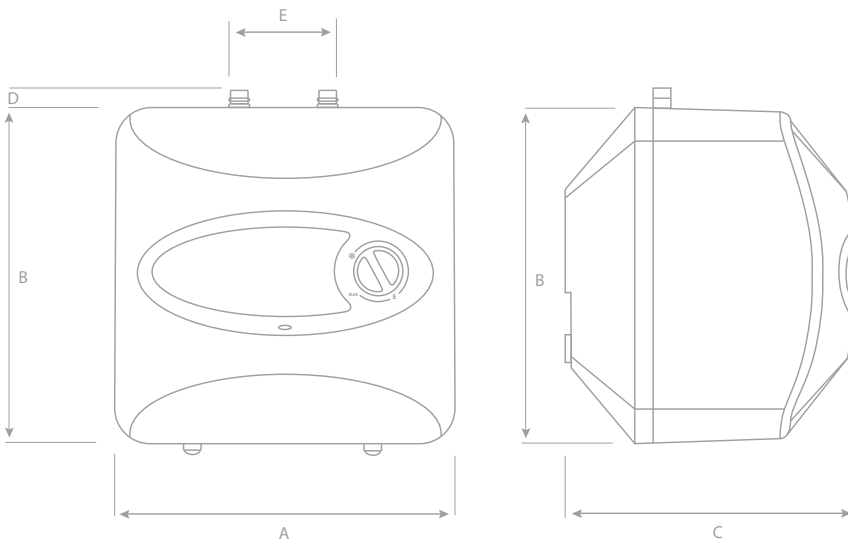

6. Troubleshooting

Sympton	Solution
Appliance not heating	Neon indicator light is not illuminated, check the thermal cut-out and reset if necessary. Neon indicator illuminated but not heating – check the heating element and replace if necessary.
Water too hot	Adjust the thermostat setting down (counter clockwise), if it does not respond then change the thermostat.
Water too cold	Adjust the thermostat setting up (clockwise), if it does not respond then change the thermostat.
Pressure relief valve discharging	If the pressure relief valve discharges only during the heating cycle, this is a sign of a lack of pipework to accommodate expansion. Check the incoming pipework for non-return devices and remove if safe to do so (see diagrams A-D).
	If the pressure relief valve is discharging permanently, this is likely to be a result of the incoming water pressure exceeding 6 bar. A pressure reducing device should be fitted to reduce the incoming water pressure.

7. Guarantee and service policy

This product is covered by a standard parts or replacement warranty for a period of three years for the tank and one year for all other parts from the date of purchase.

If there is a manufacturing defect within the warranty period we will send spare parts, repair and return the unit or, at our discretion, supply a replacement product.

Incorrect installation, frost damage, consequences of limescale deposits and failure to follow correct operating instructions are excluded. Consequential costs such as labour charges or damage to surroundings are expressly excluded.

Contact us

If you experience a problem with this product you should first contact our service department on 01924 225 200 before taking any further action.

Experience has shown that issues can often be resolved without the need to return or uninstall the product.



INFORMATION FOR CORRECT DISPOSAL OF THE PRODUCT IN ACCORDANCE WITH THE EUROPEAN DIRECTIVE 2012/19/EU.

At the end of its working life this equipment must not be disposed of as household waste. It must be taken to a local authority waste collection centre or to a dealer providing this service. Disposing of electrical and electronic equipment separately enables its components to be recovered and recycled to obtain significant savings in energy and resources. In order to underline the duty to dispose of this equipment separately, the product is marked with a crossed out dustbin.

Hycos Manufacturing Ltd
Normandy Court
Express Way
Castleford, WF10 5NR

T 01924 225 200
F 01924 225 210
E sales@hycos.co.uk

hycos.co.uk