

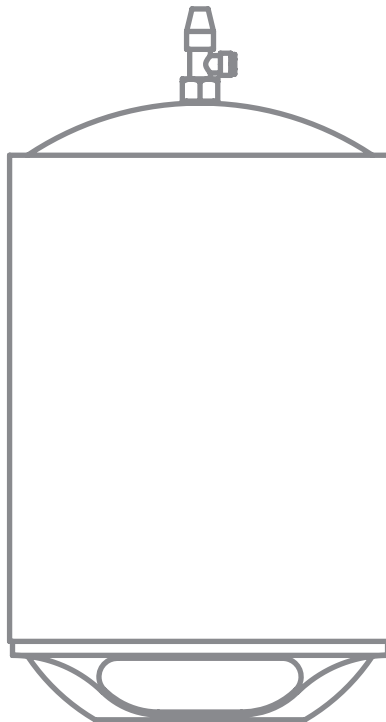

Product Instruction Manual

# Powerflow Smart



**PF30, 50, 80 & 100 litres**  
Unvented water heater

Thank you for purchasing a Powerflow series unvented electric water heater. The Powerflow is suitable for hand washing and dishwashing where a number of hot outlets are required such as kitchens, schools, restaurants, washrooms and offices. The Powerflow is the ideal solution for light industrial, commercial and light domestic hot water requirements.

Please read and understand these instructions before commencing installation and leave them with the user when installation is complete.

## 1. Important safety points



Installation must be undertaken by a competent installer of unvented water heating systems in accordance with building regulations G3.



Building regulations G3 require a temperature and pressure relief valve to be factory fitted. This must not be removed or blocked in any way.



This appliance should only be installed and maintained by a competent person in accordance with any local electrical regulations.



These units are very heavy. They must be securely fastened to a suitably strong wall using the fixings supplied. Remember to allow for the weight of the water (1kg per litre capacity) when assessing the suitability of the fixing surface.

## 2. Installation

Component check list	Qty
Expansion vessel ½" MBSP, pre-charge pressure 3.5bar	1
Vessel mounting bracket & banding	1
3 in 1 Inlet group - Single check valve, Pressure reducing valve & expansion relief valve. 15/22mm compression fittings. Including 3/4" FBSP expansion vessel port & optional 15/22mm balance off-take.	1
Tundish 15mm to 22mm	2
Tank wall mounting brackets	2

## Wall Mounting

Plan your installation carefully in advance, allowing suitable space for installation and future access to all fittings as shown in diagram 2.



The unit must be installed vertically with water connection pipes at the bottom and the pressure temperature relief valve at the top.



Ensure the mounting surface is strong enough to support the heater, including the added weight when full of water.



The heater is not suitable for installation outside.



Do not install the heater where there is any risk of freezing.



The heater is bulky and heavy, do not attempt to lift alone.

Allow at least 500mm below and 200mm above the heater to facilitate future maintenance.

To mount the heater, drill two holes for the supplied wall fixings and hang the heater onto them via the bracket at the rear.

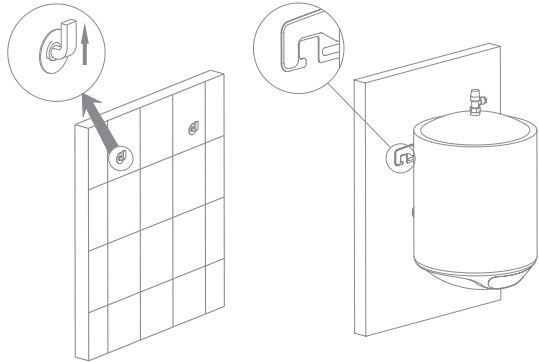

Diagram 1

## Plumbing connection

Plan your installation carefully in advance, allowing suitable space for installation and future access to all fittings as shown in diagram 2.

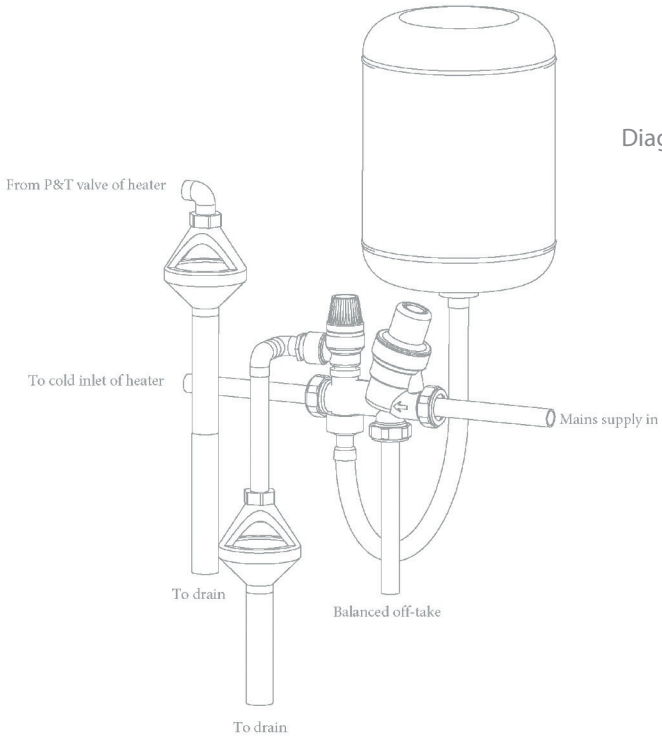

Diagram 2



Observe the flow direction arrows on fittings.



Do not insert any other valves between the 3 in 1 manifold and heater inlet since it may prevent the safe expansion and discharge of water during heating cycles.



Do not remove the factory fitted pressure and temperature relief valve.

*Plumbing connections (continued)*

It is strongly recommended that a service valve(not supplied) is fitted upstream of the 3 in one inlet group to allow for future maintenance of the unit and related fittings.

Make the necessary connections, as per diagram 2, to inlet side of the heater (as indicated by the blue collar).

It is recommended that the “balanced off take” is used to supply any cold outlet that is paired to a mixer style tap supplied by the hot feed of the unit.

The orientation of the expansion vessel is important, it should be fixed firmly to the supplied bracket in a vertical orientation with the water connection at the bottom and located so that the length of the connecting pipework is kept to a minimum.

A drain cock (not supplied) should be fitted to a branch of the incoming supply pipe at a point that is lower than both the unit and the expansion vessel in order to allow full drain down for any future maintenance work.

Make the connection to any hot tap from the outlet side of the heater as (as indicated by the red collar).

## Discharge pipe connections

This product falls within the scope of Building Regulation G3 which stipulates certain conditions relating to the way any water discharge from relief valves is transported away.

These conditions are designed to ensure that any discharge will not present a hazard to people or to property, and that any discharge is clearly visible so that the underlying cause is likely to be rectified promptly.

The essential requirement of G3 in relation to water discharge is that the discharge pipe **MUST** terminate in a safe, visible position.

In achieving this aim the G3 regulations strongly recommended that:

- The tundish is located within 500mm of the Pressure and Temperature Relief valve and it is wherever possible oriented vertically. It must be visible to occupants and positioned away from electrical devices.
- The discharge pipe has a vertical fall of at least 300mm immediately below the tundish.
- The discharge pipe below the tundish is at least 22mm diameter (i.e. one size larger than the Pressure and Temperature Relief valve outlet).
- The discharge pipe should be as straight and as short as is possible and positioned away from electrical components.

Diagram 3 illustrates an acceptable discharge pipe arrangement. The table below the diagram specifies how the maximum acceptable pipe length from the tundish to the final outlet depends on the pipe diameter and the number of bends.

For example, in 22mm copper with no bends the pipe could be up to 9m long. With two bends present the maximum length drops to  $9.0\text{m} - (2 \times 0.80\text{m}) = 7.4\text{m}$ .

Diagram 3

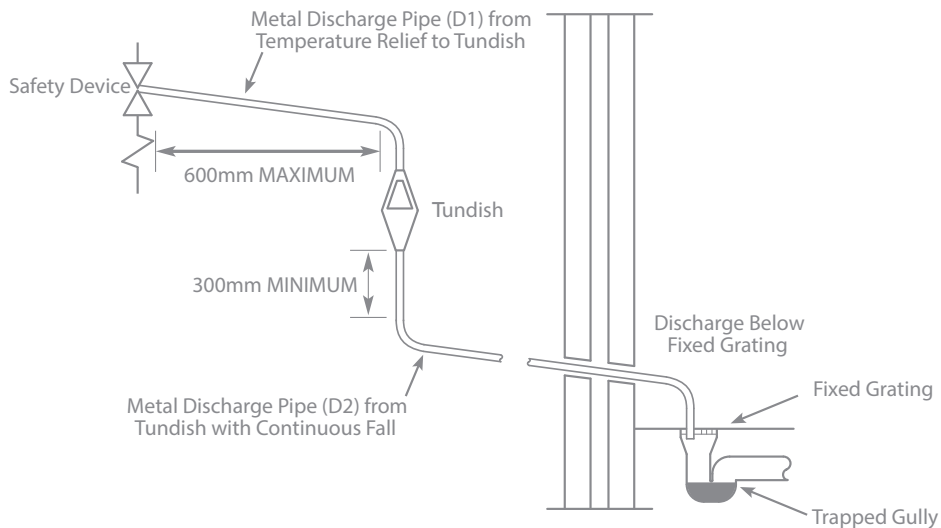

Sizing of D2 Copper Discharge pipe for common temperature relief valve outlet size				
Valve outlet size	Minimum size of discharge pipe (D1)	Minimum size of discharge pipe (D2) from Tundish	Maximum resistance allowed, expressed as a length of straight pipe (I.E. no elbows or bends)	Resistance created by each elbow or bend)
G1/2	15mm	22mm 28mm 35mm	up to 9m up to 18m up to 27m	0.8m 1.0m 1.4m

## Electrical connections

The heater is supplied pre-wired with the appropriate cable.

This appliance should only be installed and maintained by a competent person in accordance with any local electrical regulations.

Electrical supply should be capable of isolation via a user-accessible double isolation switch rated for 13A supply.

Diagram 4

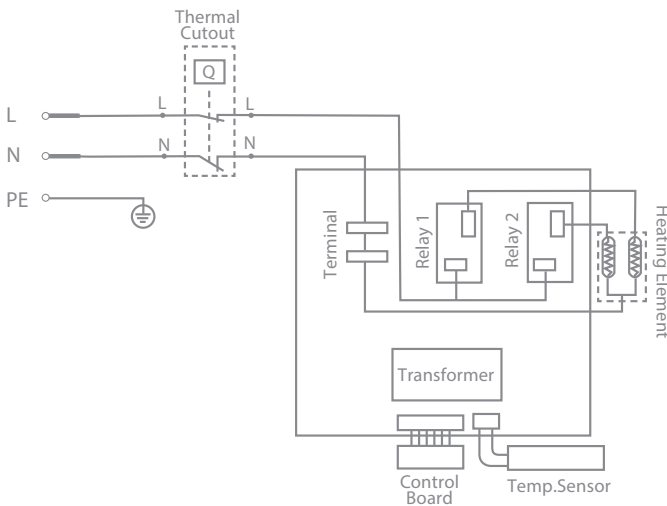

### 3. Commissioning

Visually confirm all plumbing and electrical connections look sound.

Open any tap connected to the hot side of the unit and then turn on the incoming water supply to the heater.

Allow the unit to fill until water flows smoothly from the open tap for around 1 minute to ensure the tank is purged of air and any plumbing related debris.

Close the tap and then inspect the system for any leaks.

Check the Pressure and temperature relief valve by twisting the cap to the open position and observing the flow at the tundish. Ensure the discharge pipe can cope with this flow continuously for several seconds.

Release the cap and check that the valve reseals.

Check the pressure (expansion) relief valve by twisting the cap to the open position and observing the flow at the tundish. Ensure the discharge pipe can cope with this flow continuously for several seconds. Release the cap and check that the valve reseals.

Turn on the electrical power and press the standby power button to check the display operates.

Anti Legionella Mode comes factory set as 'OFF' which is indicated by the blue status light under the temperature display.

## 4. Operation

When power is connected to the heater the display will illuminate.

On first power on, the heater will start in standard mode. To alter the target temperature of the heater, use the up/down buttons to cycle to the desired setting. The temperature is selectable between 30°C and 70°C.

The target temperature will display and flash for several seconds before the actual temperature of the water in the heater is then displayed.

To cycle through the different modes, use the 'mode' button.

Smart mode – When the Smart mode is selected, the unit will automatically heat to full temperature and then monitor the usage for the coming week. In the second week the unit will adjust its heating times to match the usage demand of the first week. This will help to reduce energy wastage during long periods of non-use e.g. overnight.

ECO mode – When the Eco mode is selected, the unit will target a maximum storage temperature of 50°C. The total available hot water will be reduced along with standing losses. This is recommended for low draw off scenarios, where larger draw offs are required select either the standard or Smart operating functions.

Standard mode – To take back control of the heater temperature from either Smart/Eco mode, press the mode button.

### Anti-Legionella Mode

When Anti-Legionella Mode is enabled, the Powerflow will heat the internal water temperature to 65°C and maintain this temperature for 1 hour once 65°C has been reached. If water is drawn during this 1-hour period, the cycle will restart.

This mode runs automatically every two weeks, based on the date and time the cycle was first performed.

To Turn On/OFF Anti Legionella Mode, when the unit is on, press and hold "Mode" for 2 seconds. The display will show "00" if Anti Legionella Mode is "OFF" and "01" if Anti Legionella Mode is "On". Use the "Mode" button to change it from 00 (OFF) or 01 (ON).

### **Anti legionella status**

Blue – Anti legionella status is off

Orange – Anti legionella status is on and currently running

Purple – Anti legionella status is on and not running



The maximum temperature setting of the heater is 70<sup>0</sup>C, this can be excessively hot for some situations/users. In situations where very young children, the elderly or other vulnerable people are likely users a suitably rated thermostatic mixing valve should be fitted to the hot water outlets as required.



Never interfere with any of the safety devices.



Beware that very hot water could discharge from the safety valves.



If a risk of frost is present the heater should be left on at least the minimum setting to prevent potential damage to the product or property from frozen pipes. If the heater is going to be left unused for a long period of time it should be drained.

## 5. Maintenance



Always disconnect the heater from the power supply before commencing any maintenance task.



Servicing of electrical components should only be undertaken by competent individuals.

### Draining the unit

To drain the unit, first isolate both the incoming power and water supply.

Open the drain cock on the cold inlet and open a hot outlet to enable air to replace the draining water.

A small amount of water may remain in the tank following a full drain down. This residual water can be drained by removing the heating element.

### **Resetting the thermal cut-out**

To remove the access panel from the bottom of the unit, first remove the screw towards the back of the unit. To unclip the panel from the base of the unit, gently prise the cable at the cable entry point to release from the lug at the front.

Remove the insulation from inside the heater.

Locate and push the button in the centre of the thermal cut-out to reset the unit.

If a cut-out event re-occurs, contact the technical team at Hyco on 01924 225200 for further advice.

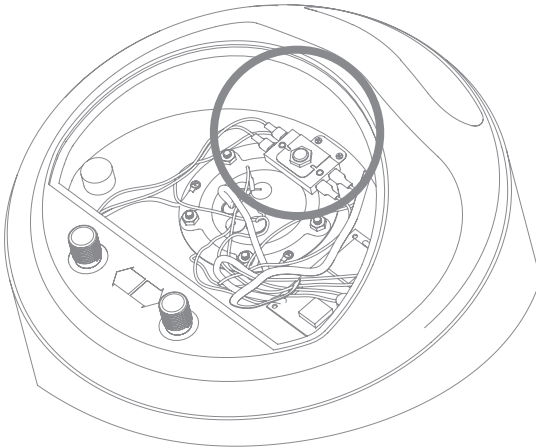

## Removing the element

To remove the access panel from the bottom of the unit, first remove the screw towards the back of the unit. To unclip the panel from the base of the unit, gently prise the cable at the cable entry point to release from the lug at the front.

Remove the insulation from inside the heater.

Locate and disconnect the Live and Neutral terminals.

Remove the Thermistor and thermal cut-out probes by gently pulling them from the element pocket.

Remove the two screws that connect the thermal cut out to the body of the unit and move the cut-out to the side to reveal the fifth nut. Remove the five nuts from the retaining ring of the heating element and this will release and allow full removal of the heating element.



If the earthing points are removed always ensure a firm reconnection before re-commissioning of the heater.



Always ensure the the two probes are replaced back into element pocket fully, the unit will malfunction otherwise

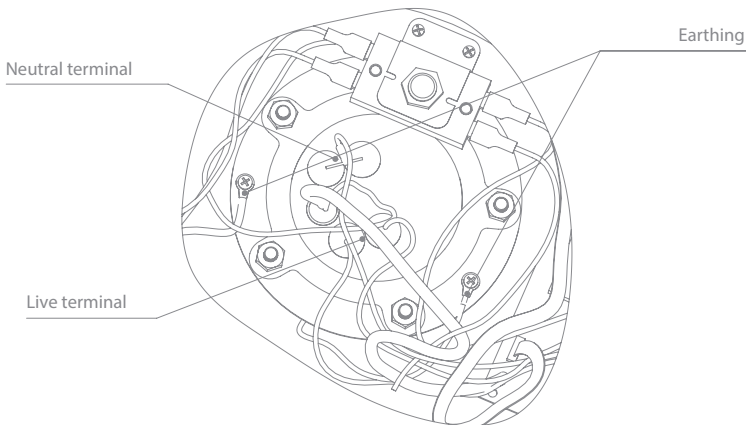

**De-scaling procedure**

Scale can build up over time and if unchecked will lead to impaired heating element performance and lifespan. For this reason, Hyco strongly recommends regular inspection of the inner tank and descaling as required.

To access the inner tank, it is necessary to fully drain the tank and remove the heating element (see relevant sections in this manual).

Remove scale carefully. If required, dip the heating element in a de-scaling solution (commonly available from DIY/plumbing outlets). Take good care not to wet the electrical connections of the heating element.

It is not normally necessary (or practical) to remove scale from the tank wall.

Refit the heating element and follow the commissioning section of this instruction to complete the process.

### **Anode & tank inspection**

A sacrificial magnesium anode is fitted to the heating element of this product. It is normal for this to break down overtime as this helps to prevent other parts of the tank/element from doing likewise.

Once the anode is significantly eroded it will no longer offer protection to the tank /element.

In order to prolong the life of the heater it is recommended that the anode is inspected at least annually (more often in known water quality problem areas) and replaced as necessary.

To inspect/replace the anode, the heater must first be drained, and the heating element removed (see relevant sections in this manual).

While the element is removed, the inside of the tank should be inspected, a torch may be necessary, to check for signs of rusting anywhere on the inside of the tank lining. If the element is found to be sound but rust is present inside the unit this may be a sign of the enamel lining of the tank failing, and further investigation should be undertaken before re-commissioning the unit. Contact the Hyco technical support on 01924 225200 for further advise.

### **Safety valve inspection**

The pressure & temperature valve and the pressure (expansion) relief valves are important safety features of the heater and should be tested periodically to ensure correct functioning. To test the valves, twist the caps and check that water flows freely. The tundish will allow for visual confirmation that water is flowing during the test.

### **Pressure reducing valve maintenance**

Isolate the water supply to the pressure reducing valve. Unscrew the plastic cap of the pressure reducing valve and remove the complete mechanism from the brass housing of the valve.

Check there is no debris or grit build in the wire mesh and remove by rinsing as required. Replace the mechanism into the brass housing and then recommission the heater (see relevant sections in this manual). Particular attention should be given to ensure the mechanism has been seated correctly into the brass housing and a sound seal has been made.

### **Expansion vessel maintenance**

The expansion vessel is supplied with a pre-charge of 3.5 bar, this pressure may be lost over time and should be checked periodically to keep the vessel functioning well and help prolong the lifespan of the tank.

To check the pressure of the vessel, a reading should be taken while the unit is switched off and the content of the tank has been cooled. Turn off the power to the unit and run water off from the outlet until it is at ambient temperature, check the pressure reading and increase/decrease as required (a standard pump with built in pressure gauge is required).

### **Legionella risk advice**

- To minimise the risk of Legionella, we recommend conducting a site-specific, comprehensive Legionella risk assessment. While the Powerflow's Anti-Legionella feature ensures that water is not left at high-risk temperatures for more than two weeks, this functionality does not replace the need for a full assessment or the possibility that more stringent control measures may be required.
- The whole system should be drained if long periods of non-use are expected.
- The expansion vessel should be drained occasionally to ensure the water in it is recycled.

## 6. Specifications

MODEL	PF30LS	PF50LS	PF80LS	PF100LS
Maximum supply pressure to reducing valve	1.2 MPa			
Power	3.0 kW			
Supply voltage/frequency	230V ~/50Hz			
Current	13A			
Capacity (Litres)	30	50	80	100
Operating pressure	0.3 MPa			
Maximum tank pressure	0.7 MPa			
Expansion vessel pre-charge	0.35 MPa			
Pressure reducing valve pre-set	0.3 MPa			
Pressure relief valve rating	0.6 MPA			
Temperature & pressure safety valve rating	90 <sup>0</sup> C/0.7MPa			
Manual-reset cut out rating	80 <sup>0</sup> C			
Minimum recommended supply pressure	0.1 MPa			
Immersion heater spec	3.0kW (Incoloy with anode)			
Weight empty (kg)	14	18	24	28
Weight full (kg)	45	68	104	128
Heat up time from 10 <sup>0</sup> C to 60 <sup>0</sup> C (minutes)	35	70	120	215
Recovery time of 70% capacity to 60 <sup>0</sup> C (minutes)	27	49	84	125
Standing heat loss kW/24h	0.60	0.72	1.06	1.41
Inlet/Outlet connections	½" MBSP			

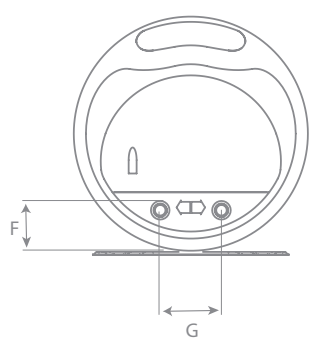
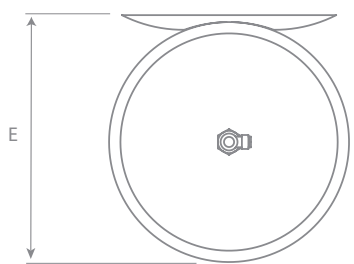
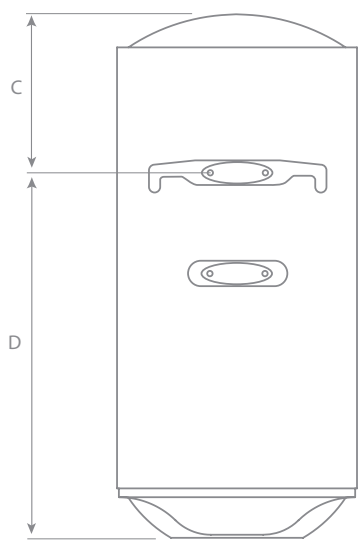
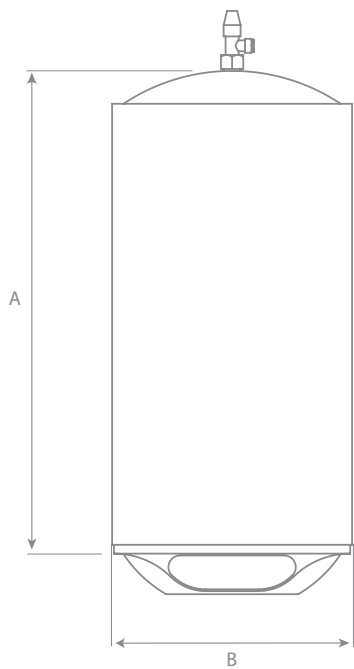

Model	A	B	C	D	E	F	G
30L	542mm	380mm	206mm	336mm	389mm	88mm	100mm
50L	762mm	380mm	226mm	536mm	389mm	88mm	100mm
80L	987mm	410mm	270mm	717mm	416mm	103mm	100mm
100L	1139mm	410mm	340mm	799mm	416mm	103mm	100mm

## 7. Troubleshooting

Symptom	Cause	Remedy
Unit not heating and display not working.	Thermal cut-out has operated.	Reset thermal cut-out (see section 5 Maintenance). If problem persists, contact hyco for further advice.
Pressure relief valve discharging on heating cycle.	Expanding hot water.	Check and alter expansion vessel charge (see section 5 maintenance)
Water too hot.	Thermostat setting too high.	Adjust thermostat down (see section 4 Operation)
Pressure relief valve discharges constantly.	Pressure too high or relief valve faulty.	Change pressure reducing valve/change pressure relief valve.
Water not heating but display working.	Faulty component(s)	Check heating element with multi meter, if faulty replace element (see section 5 maintenance). If element ok then change PCB and thermistor contact hyco for further advice.
No/limited water flow.	Obstruction in pipe-work or the heater inlet/outlet.	Check flow from pressure relief valve, if limited flow then problem could be pressure reducing valve. Inspect and clean pressure reducing valve (see section 5 maintenance).
		If pressure relief valve flows well then check the heater for limescale issue (see section 5 maintenance).

## **8. Guarantee and service policy**

This product is covered by a standard two year parts or replacement warranty on electrical components and a five year tank warranty from the date of purchase.

If there is a manufacturing defect within the warranty period we will send spare parts, repair and return the unit or, at our discretion, supply a replacement product.

Incorrect installation, frost damage, consequences of limescale deposits and failure to follow correct operating/maintenance instructions are excluded. Consequential costs such as labour charges or damage to surroundings are expressly excluded.

### **Contact us**

If you experience a problem with this product you should first contact our service department on 01924 225 200 before taking any further action.

Experience has shown that issues can often be resolved without the need to return or uninstall the product.

## **9. Approvals**

The Hyco Powerflow Smart range of water heaters complies with the LVD & EMC directives as required for the UKCA marking.

The Hyco Powerflow Smart range of water heaters have been examined, tested and found, when correctly fitted, to comply with the requirements of the United Kingdom Water Regulations/Byelaws (Scotland).



INFORMATION FOR CORRECT DISPOSAL OF THE PRODUCT IN ACCORDANCE WITH THE UK WEEE REGULATIONS.

At the end of its working life this equipment must not be disposed of as household waste. It must be taken to a local authority waste collection centre or to a dealer providing this service. Disposing of electrical and electronic equipment separately enables its components to be recovered and recycled to obtain significant savings in energy and resources. In order to underline the duty to dispose of this equipment separately, the product is marked with a crossed out dustbin.

Hyco Manufacturing Ltd  
Normandy Court  
Express Way  
Castleford, WF10 5NR

T 01924 225 200  
E sales@hyco.co.uk

**hyco.co.uk**