

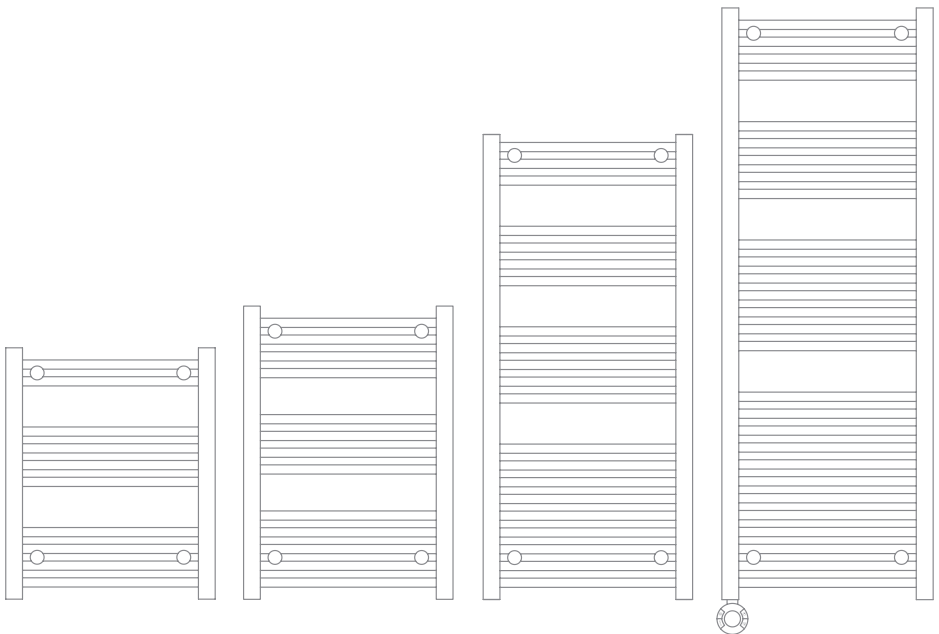

Product Instruction Manual

# AQUILO

Standard & Electronic (with Wi-Fi)



**150W, 250W, 400W & 600W**

Ladder Style Towel Rail

Standard & Electronic (with Wi-Fi)

Thank you for choosing the Hyco Aquilo straight ladder-style towel rail. Please read these instructions carefully to ensure safe installation and proper operation.

The Aquilo features a modern slimline profile, available in high-quality chrome, white & anthracite finishes. It is ideal for keeping towels warm and dry in bathroom environments.

Electronic models come with a timer module and Wi-Fi, standard models do-not have these features. Please see table in 10. Specification.

### **Key features**

- Sleek, straight ladder design
- High quality chrome, white & anthracite finish
- Simple installation

Sections 4 to 8 only apply to electronic models.

## 1. Important safety points



This appliance should only be installed and maintained by a competent person in accordance with any local electrical regulations.



Children of less than 3 years should be kept away unless continuously supervised.



Children aged from 3 years and less than 8 years shall only switch on/off the appliance provided that it has been placed or installed in its intended normal operating position and they have been given supervision or instruction concerning use of the appliance in a safe way and understand the hazards involved.



Children aged from 3 years and less than 8 years shall not plug in, regulate, and clean the appliance or perform user maintenance.



CAUTION - Some parts of this appliance can become very hot and cause burns. Particular attention has to be given where children and vulnerable people are present.



WARNING: In order to avoid a hazard for very young children, this appliance should be installed so that the lowest heated rail is at least 600 mm above the floor.



This appliance is filled with a precise quantity of special liquid. Do not attempt to fill or empty the unit.

## 2. Installation



Do not proceed with installation if there are signs of damage to the product.



If the supply cord is damaged, it must be replaced by a special cord or assembly available from the manufacturer or its service agent.



Do not install in spaces where ambient temperatures may fall below safe operating levels (typically 5°C or below). Freezing may cause system failure and void the warranty.



The appliance must not be located immediately below a socket outlet.



Ensure the mounting surface is suitable for the weight and heat of the product.



Ensure there are no hidden cables or pipework before commencing any drilling.

- Select a mounting surface that is suitable for the weight of the product (see section 10 Specification table).
- Decide the distance between the mounting bracket positions vertically and horizontally. Ensure that the brackets are spaced sufficiently to provide a safe stable fit to the wall, also consider the horizontal centres to allow towels to slide freely down the back of the rails.

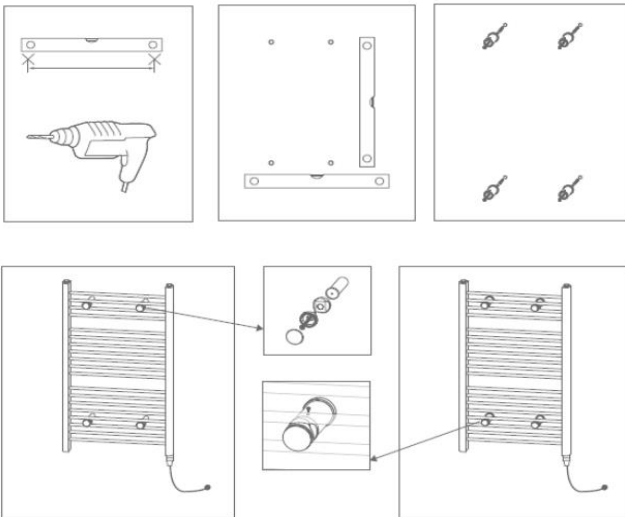

### 3. Electrical connection



Only connect the appliance to an electrical supply that meets the specification detailed on the rating label.



The appliance must be permanently connected to the electrical supply through an appropriately rated isolating switch with a contact separation in all poles.



This appliance must be earthed.

- Connection should be made to the fixed wiring of the property via a double pole switched fused spur.





**Electrical connections should be made as follows:**

Green/Yellow earth wire to the terminal marked "E" or 

Brown/Red live wire to the terminal marked "L"

Blue/Black neutral wire to the terminal marked "N"





## 4. Controls

Button	Name (Description)
	Standby Button (On/Off)
	Down Button (Decrease)
	Up Button (Increase)
	Menu Button (Mode Selection)

### LCD Display



Number	Description
1	Wi-Fi / Pairing
2	Schedule Mode (Timed Programme)
3	Free Mode (Manual)
4	Element On
5	Child Lock
6	Constant Mode (Fixed Temperature)
7	Timing Mode (Runback Timer)

Operating Mode	Symbol	Mode Description
<b>Schedule Mode</b> (Timed Programme)		This Mode allows you to create bespoke programmes for each day of the week. Temperature fixed at 65°C.
<b>Free Mode</b> (Manual)		Manual Mode, adjustable temperature between 30 - 70 °C This mode will stay on until the user turns it off.
<b>Timing Mode</b> (Runback Timer)		Runback timer allows you to dictate how long the unit is on for from 30 minutes to 8 hours. Fixed at 65°C.
<b>Constant Mode</b> (Fixed Temperature)		This mode keeps the temperature fixed at 50°C and will stay on until the user turns it off.

The temperature setting is the surface temperature of the towel rail.

## 5. Preparing the Appliance











### 5.1 Switching the Appliance On



- Switch the power supply to the appliance on
- Once there is power to the appliance, the screen will illuminate, and the appliance will be in standby mode.
- Tap the  button on the controller to activate the appliance, taking it out of standby mode. The appliance will default on first install into Schedule Mode (Timed Programme).

### 5.2 Setting the Time and Date

Below is information on how to set the time and date on the physical display. All functions can be set through the Smart Life app, making the process quicker and easier. When connected to the Smart Life app, your device will automatically sync the time and date. For more details, see Section 7 - Wi-Fi Compatibility.

If after 30 seconds nothing has been input, the unit will skip to the next step. Take time to read through each section before attempting this next step.

- The appliance will default in Schedule mode (Timed programme). This mode is represented by the  symbol on the display. If the appliance is not in this mode, use the  button to cycle through the four modes.
- In  mode, hold the  button for three seconds, after which the hour will begin to flash.
- Use the  or  arrows to select the hour and tap  to confirm
- Use the  or  arrows to select the minutes and tap  to confirm

- Use the  or  arrows to select the day of the week. (These are represented by numbers. Monday to Sunday 1 – 7. If you were setting the appliance on a Tuesday, you would select 2). Tap  to confirm.
- Your time and date are now set. Your display will now show P1 which leads into setting your daily schedules. Please move to section 6.1.4 Schedule Mode (Timed Programme) for more detail.

**Please note: If power to the unit is lost, the set time and date will be cleared. You will need to follow the above instructions to reset the appliance. If your unit is connected to the app, the time and date will automatically resync within approximately 30 seconds**

## 6. Operation

### 6.1 Selecting the Operating Mode





When the unit is out of standby, tap the

MENU

button to cycle through the four operating modes.



#### 6.1.1 Free Mode (Manual)



- Free Mode (Manual) is the simplest way to use your appliance. There are no timers running. The thermostat will control the heating element to reach and maintain the target temperature.
- Whilst  is displayed on the screen, the appliance is turned on. Use the  or  arrows to adjust the temperature. The temperature is adjustable between 30 – 70°C. You can hold the  or  arrows down to cycle through faster.

#### 6.1.2 Timer Mode (Runback Timer)



- Timer Mode (Runback Timer) is ideal when you want the appliance to turn off automatically after a set period. You can program it in 30-minute increments, up to a maximum of 8 hours.
- Use the  or  to select the desired duration. Once you've made your selection, simply allow the unit to return to idle - the setting will be saved automatically. When the selected time has elapsed, the appliance will switch off.

#### 6.1.3 Constant Mode (Fixed Temperature)



- Constant Mode is ideal when you need the unit to remain on continuously without any temperature adjustment. In this mode, the temperature is fixed at 50°C and cannot be adjusted. The unit will maintain this temperature indefinitely until manually turned off by the user.

#### 6.1.4 Schedule Mode (Timed Programme)



Below is information on how to set the programmable timer on the physical display. All functions can be set through the Smart Life app, making the process quicker and easier. Please see Section 7 - Wi-Fi Compatibility.



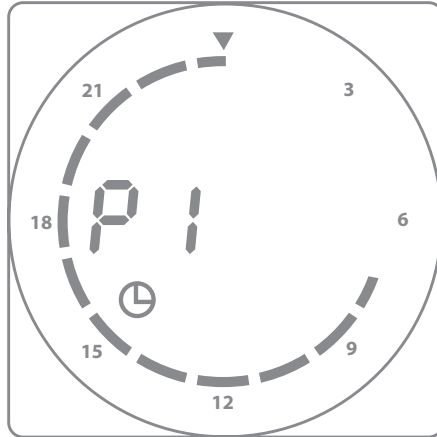

- Schedule Mode (Timed Programme) is ideal if you want to set custom on and off times, with the flexibility to program different times for each day of the week.
- When the appliance is operating in Schedule Mode (Timed Programme), it will follow the programmed schedule for the current day. For example, if today is Tuesday, the appliance will follow Programme 2 (P2).
- To use this feature, please refer to (Section 4: Preparing the Appliance – Setting the Time and Date). Once the correct day of the week is confirmed, Programme 1 (P1) which represents Monday will be displayed by default.

## 6.2 Creating a Custom Programme







- The appliance comes preset with a default schedule: 'OFF' between 00:00 and 07:00, and 'ON' between 07:00 and 00:00, as illustrated in the example below.
- A fully shaded segment represents an hour when the unit is 'ON' and heating, while an unshaded (blank) segment indicates an hour when the unit is 'OFF' and not heating.





### 6.3 Modifying Schedules

- With P1 displayed on the screen (as shown in the image on the previous page), press & hold the  button for 3 seconds. P1 will remain illuminated, and “:00” will appear next to it. The segment representing that hour will begin to flash.
- The flashing segment and corresponding hour indicate the time slot you are currently programming. For each hour, you can choose whether the appliance should be ‘ON’ (Heating) or ‘OFF’ (Not Heating). Use the arrow buttons to set each hour to either ‘ON’ or ‘OFF’, depending on your desired schedule.
- Tapping the  arrow will set the flashing hour segment to be ‘ON’ (Heating), While tapping the  arrow will set it to ‘OFF’ (Not Heating)
- If you prefer to start with a blank schedule, you can clear all segments by repeatedly pressing the  arrow until no segments are illuminated. Then, press the  arrow to select your desired ‘ON’ (Heating) hours.

### Example: Setting the Unit to Heat from 07:00 – 09:00 and 18:00 – 20:00

- 1. With P1:00 showing on the display, press the  arrow repeatedly until the display reads P1:07. This represents 07:00 - your first hour 'ON' (Heating).
- 2. Now press the  arrow until the display shows P1:09. This sets the heating period from 07:00 to 09:00. You will now see two full shaded segments for 07:00 and 08:00, indicating the unit is set to heat during those hours.
- 3. With the display now at P1:09, press the  arrow until it reads P1:18. This means the unit will remain 'OFF' (Not Heating) between 09:00 and 18:00.
- 4. Press the  arrow until the display reads P1:20 to set the second heating period from 18:00 to 20:00.
- 5. To complete the cycle, press the  arrow until the display returns to P1:00.
- 6. Press the  button to save your settings. Leave the appliance to go idle - it will automatically begin operating according to your programmed schedule.
- You will now need to repeat this process for each day of the week. P1 represents Monday's schedule, P2 is Tuesday's, and so on through to P7 for Sunday.
- To cycle through the daily schedules, press the  button while P1 is displayed. This will allow you to scroll through P1 to P7. For each day, follow the same steps outlined above to set your desired heating times.

### 6.4 Child Lock

- Press the  and  buttons simultaneously for 3 seconds while the unit is active (not in standby mode). The lock symbol will appear on the display, indicating that the controls are now locked. In this state, the only functions available are turning the unit on or off.
- To unlock the controls, simply repeat the same steps.

## 7. Wi-Fi Compatibility

• Download the “Smart Life” App on your smartphone. Application Store (Android) or App Store (IOS). Alternatively, scan the below QR code to download, install and create an account by following the in-app instructions.



### Wi-Fi Requirements

- Smart Life devices REQUIRE a 2.4 GHz Wi-Fi network.
- 5 GHz networks are NOT supported.
- If your router is dual-band, it is a good idea to give the 2.4 GHz and 5 GHz networks different names (SSIDs) so you can select the correct one during setup.
- Ensure your Wi-Fi uses standard security (WPA2-PSK/AES) - this is the default on most modern routers.
- Place the device within good Wi-Fi range for a stable connection
- To change or check your Wi-Fi settings, consult your router’s instruction manual.

### Pairing Your Appliance

- When the appliance is in standby mode, press and hold the  button for 3 seconds to enter pairing mode. The appliance will stay in pairing mode for 100 seconds. This is indicated by a shaded line that gradually traces around the display, forming a rectangular outline, this can also be seen in the below display.



- If you are already signed into the smart life app and connected to a 2.4GHz Wi-Fi network when you have the smart life app open and the appliance is in pairing mode, you should be prompted to pair the device.

## 8. App Setup Instructions



### Wi-Fi Requirements

- Smart Life devices REQUIRE a 2.4 GHz Wi-Fi network.
- 5 GHz networks are NOT supported.
- If your router is dual-band, it is a good idea to give the 2.4 GHz and 5 GHz networks different names (SSIDs) so you can select the correct one during setup.
- Ensure your Wi-Fi uses standard security (WPA2-PSK/AES) - this is the default on most modern routers.
- Place the device within good Wi-Fi range for a stable connection
- To change or check your Wi-Fi settings, consult your router's instruction manual.

### 8.1 Connecting Your Appliance

1. Open the Smart Life app.



2. Go to the Home section, located at the bottom of your screen.

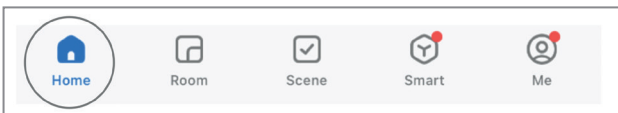

3. In the top-right corner, tap the + icon.



4. From the four options that appear, select Add Device.

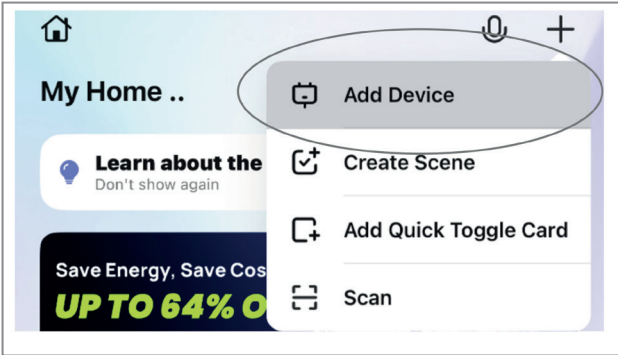

5. The app will begin searching for devices. Make sure your appliance is in pairing mode.

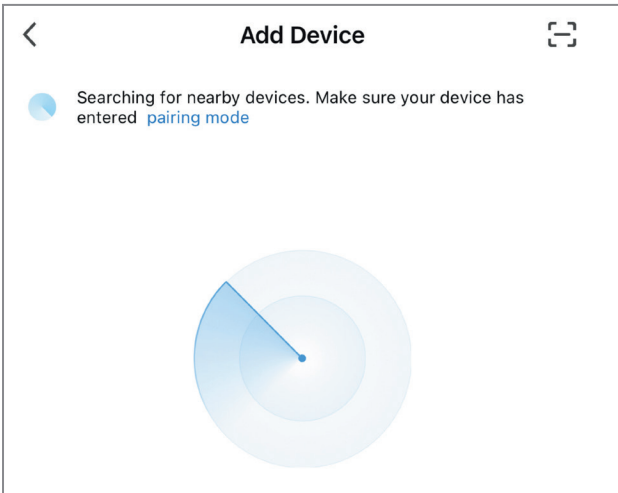

6. When your appliance appears, tap the controller icon, then tap Add.

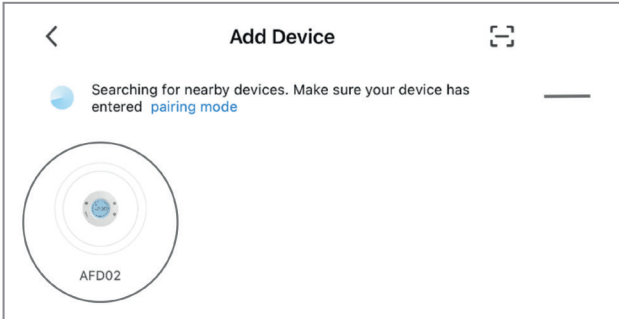

7. Enter your Wi-Fi password when prompted. Make sure to use the same Wi-Fi network your phone is connected to

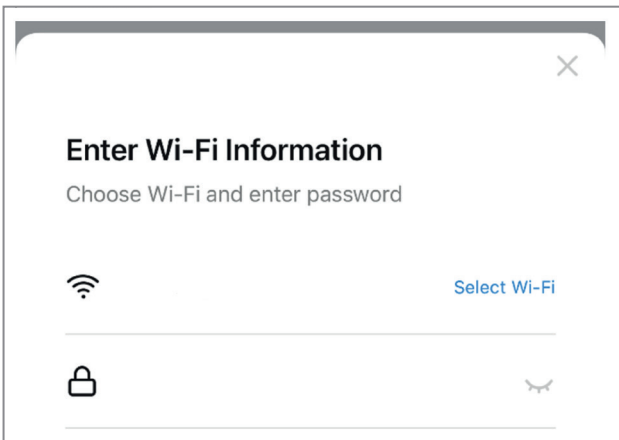

8. Tap Next to continue.

9. After pairing, check for a green tick and the “Added Successfully” message under the product name.

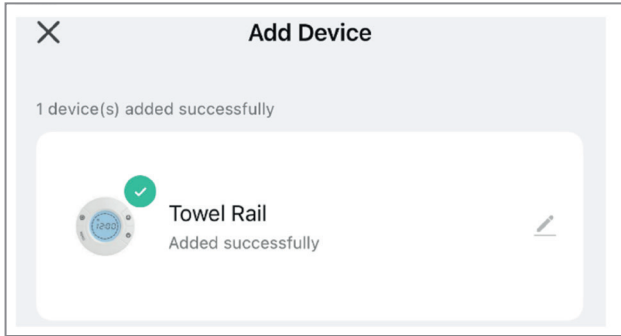

10. Tap Done to proceed.

## 8.2 Operating the Appliance

11. Appliance will now be in standby mode after initial pair. You can confirm the appliance is in standby mode when the 'Mode' option at the bottom of your device display is faded, and the 'Switch' button is not illuminated orange.

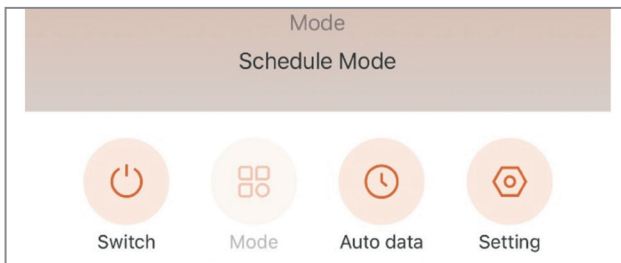

12. Press the Switch button to take the appliance out of standby mode.

**13.** On first installation, the unit will default to Schedule Mode.

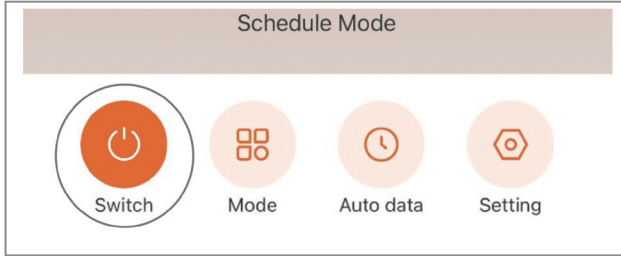

**14.** Press the Mode button to view the four available modes.

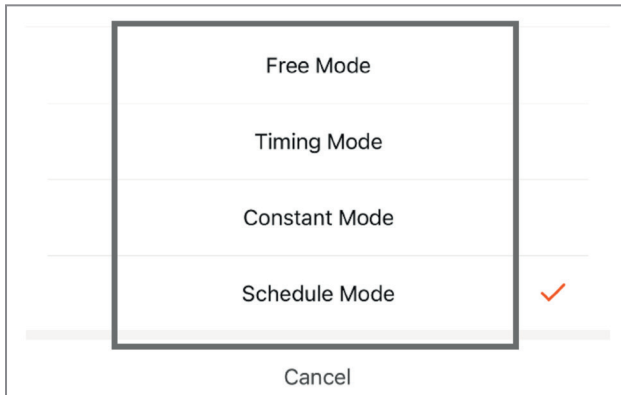

### 8.3 Using Schedule Mode (Timed programme)

**16.** On the appliance control home screen, select Schedule Mode.

**17.** Tap the Auto Data button.

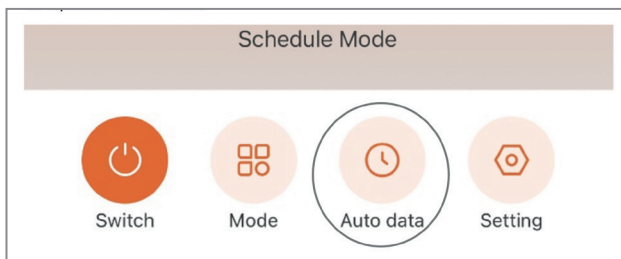

**18.** View the preset weekly schedule:

- Green = No Heat (Off)
- Red = Heat (On)

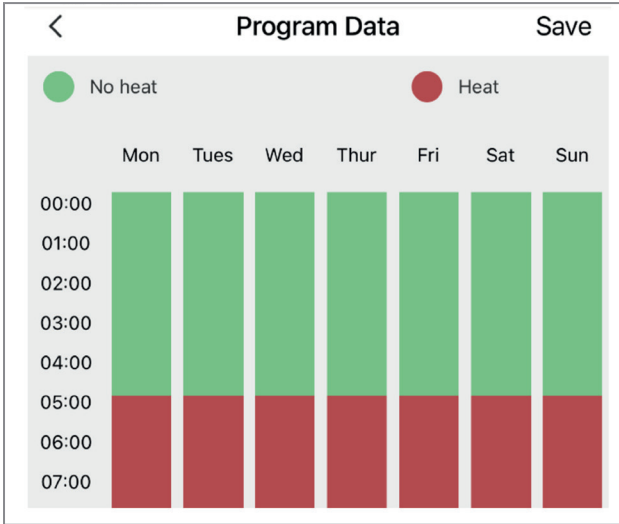

**19.** To edit the schedule:

- Tap an hour segment.
- Select Green for No Heat or Red for Heat.
- The segment will update.

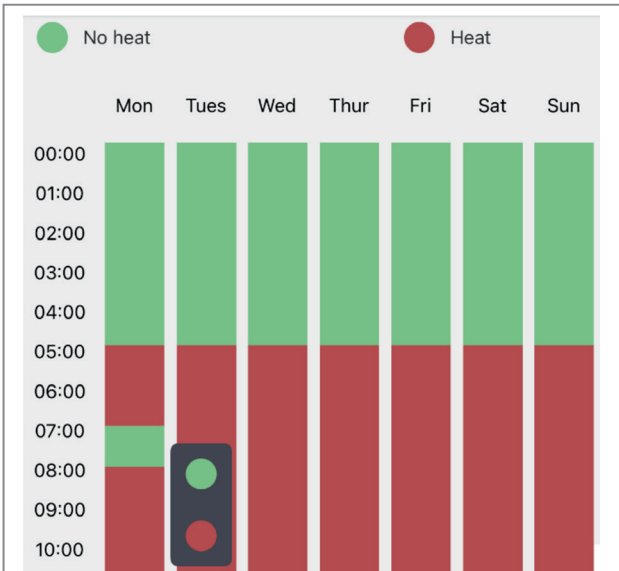

20. Example personalised schedule:

- On at 07:00 → Off at 09:00 → On at 17:00 → Off at 20:00.

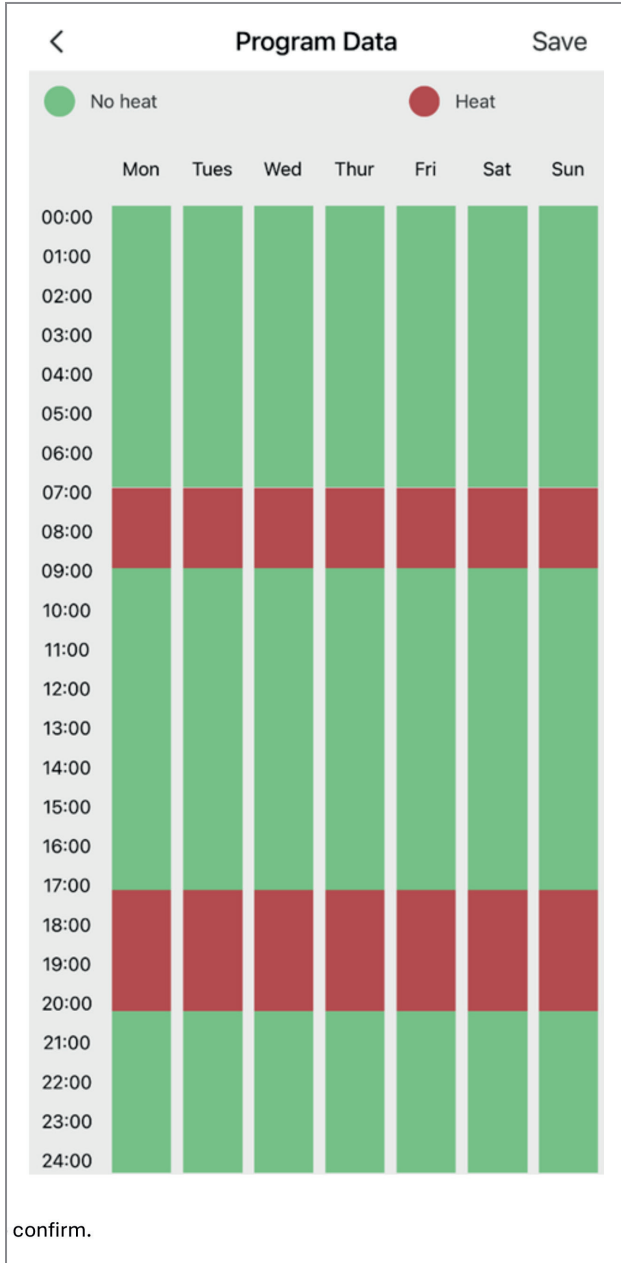

## 9. Maintenance



Allow the appliance to cool down before undertaking any maintenance.



Isolate the electrical supply before undertaking any maintenance work.

The surface of the appliance should be wiped clean with a soft cloth and soapy water.

**Do not use abrasive chemicals or cloths as damage may result.**

## 10. Specification

Model	AQ150LS / AQ150LW / AQ150LAE / AQ150LSE	AQ250LS / AQ250LW / AQ250LAE / AQ250LSE	AQ400LS / AQ400LW / AQ400LAE / AQ400LSE	AQ600LSE
<b>Voltage</b>	AC 230V	AC 230V	AC 230V	AC 230V
<b>Frequency</b>	50Hz	50Hz	50Hz	50Hz
<b>Power</b>	0.15 kW	0.25 kW	0.40 kW	0.60 kW
<b>Ingress Protection</b>	IP24	IP24	IP24	IP24
<b>Height (mm)</b>	600*	700*	1100*	1400*
<b>Width (mm)</b>	500	500	500	500
<b>Depth (mm)</b>	105	105	105	105
<b>Weight (kg)</b>	6.3	8.1	12.5	14.5

\* Electronic models include an additional 70mm in height to accommodate the timer module.

Model	Finish	Electronic
AQ150LS/AQ250LS/AQ400LS	Chrome	No
AQ150LW/AQ250LW/AQ400LW	White	No
AQ150LAE/AQ250LAE/AQ400LAE	Anthracite	Yes
AQ150LSE/AQ250LSE/AQ400LSE/AQ600LSE	Chrome	Yes

## **11. Guarantee and service policy**

This product is covered by a standard parts or replacement warranty for a period of two years from the date of purchase.

If there is a manufacturing defect within the warranty period we will send spare parts, repair and return the unit or, at our discretion, supply a replacement product.

Incorrect installation, frost damage, consequences of limescale deposits and failure to follow correct operating/maintenance instructions are excluded. Consequential costs such as labour charges or damage to surroundings are expressly excluded.

### **Contact us**

If you experience a problem with this product you should first contact our service department on 01924 225 200 before taking any further action.

Experience has shown that issues can often be resolved without the need to return or uninstall the product.







INFORMATION FOR CORRECT DISPOSAL OF THE PRODUCT IN ACCORDANCE WITH THE UK WEEE Regulation

At the end of its working life this equipment must not be disposed of as household waste. It must be taken to a local authority waste collection centre or to a dealer providing this service. Disposing of electrical and electronic equipment separately enables its components to be recovered and recycled to obtain significant savings in energy and resources. In order to underline the duty to dispose of this equipment separately, the product is marked with a crossed out dustbin.

Hyco Manufacturing Ltd  
Normandy Court  
Express Way  
Castleford, WF10 5NR

T 01924 225 200  
E sales@hyco.co.uk

**hyco.co.uk**